



## Summary of State Rules on Mud Flap/ Splash Guard Requirements Updated: March 2014

### Alaska – 13 AAC 04.265

#### Anti-Spray Device

- Alaska refers to mud flaps as anti-spray devices under 13 AAC 04.265. The state requires that any motor vehicle of sufficient height operated on public roads must be equipped with such a device, which will reduce wheel spray to the rear of the vehicle.

#### Installation Factors

- Alaska Administrative Code 13 AAC 04.265 requires that anti-spray devices must be installed and maintained so that the device is placed directly behind the wheel. The mud flap must extend downward to a distance of 14 inches from the ground, as measured when the vehicle is standing over level ground.

#### Wheel Coverage

- Alaska's mud-flap requirements are intended to protect other vehicles from water and debris that may be kicked up from a vehicle's tire, particularly where the vehicle and tires are oversized. It is one part of Alaska's efforts to ensure that exposed tires do not cause unnecessary damage on Alaskan roads. Alaska also restricts vehicle height. Under 13 AAC 04.005, vehicles are restricted in the amount of height (lift) a vehicle may have with a maximum frame height or body floor height of 24 inches for a vehicle up to 4,500 lb.

### Arizona – Title 28- Transportation 28-958.01

#### Rear fender splash guards

- A. A person shall not operate a truck, trailer, semitrailer or bus on a highway unless the vehicle is equipped with rear fender splash guards that comply with the specifications provided in this section.
- B. The splash guards:
  1. Shall be attached in a manner that prevents the splashing of mud or water on the windshield of other motor vehicles.
  2. Shall extend to a length of not more than eight inches from the ground.
  3. Shall be wide enough to cover the full tread or treads of the tires being protected.
  4. Shall be installed close enough to the tread surface of the tire or wheel to control the side throw of the bulk of the thrown road surface material.
  5. May be constructed of a flexible rubberized material.
  6. Shall be attached in a manner that, regardless of movement either in the splash guards or the vehicle, the splash guards retain their general parallel relationship to the tread surface of the tire or wheel under all ordinary operating conditions.
- C. This section does not apply to:
  1. A vehicle commonly known as a pickup truck with a manufacturer's gross vehicle weight rating of ten thousand pounds or less, except that this section applies if the pickup truck has been modified from the original bumper height design to raise the center of gravity of the pickup truck.
  2. A truck tractor or converter dolly when used in combination with another vehicle.
  3. A single, tandem or triple axel trailer with fenders that are wide enough to cover the full tread or treads of the tires being protected and that extend to a length of not more than fourteen inches from the ground.

### California – California Department of Motor Vehicle Code Section 27600

#### Fenders and Mudguards

- No person shall operate any motor vehicle having three or more wheels, any trailer, or semitrailer unless equipped with fenders, covers, or devices, including flaps or splash aprons, or unless the body

of the vehicle or attachments thereto afford adequate protection to effectively minimize the spray or splash of water or mud to the rear of the vehicle and all such equipment or such body or attachments thereto shall be at least as wide as the tire tread. This section does not apply to those vehicles exempt from registration, trailers and semitrailers having an unladen weight of less than 1,500 pounds, or any vehicles manufactured and first registered prior to January 1, 1971, having an unladen weight of less than 1,500 pounds.

#### **Connecticut – General Statute Section. 14-104**

##### Fenders and other wheel protectors

- (a) No person shall operate on any public highway any motor vehicle with a passenger or commercial registration which is not equipped with fenders on all wheels which come into contact with the highway unless the body of the vehicle or attachments thereto afford adequate protection to effectively minimize the spray or splash of water or mud to the rear of the vehicle.
- (b) No person shall operate or cause to be operated any bus, truck, truck-tractor, full trailer or semitrailer of registered gross weight exceeding three tons on any public highway unless the same is equipped with suitable metal protectors or substantial flexible flaps behind the rearmost wheels, and, in case the rear wheels are not covered at the top and rear by fender, body or other parts of the vehicle, the rear wheels shall be covered at the top and rear by protective means of such standard type or design and so installed as to reduce, as far as practicable, such wheels from throwing dirt, water or other materials on the windshields of following vehicles, except in cases in which the motor vehicle is so designed and constructed that the above requirements are accomplished by reason of the fender or body construction or other means of enclosure.
- (c) Violation of any provision of this section shall be an infraction.

#### **Delaware – Delaware Code- Section 4317**

##### Protectors or Flaps behind Rear Wheels of Vehicles

- (a) No person shall operate, cause or permit to be operated any bus or commercial motor vehicle having a gross weight of 8,000 pounds or more, including semitrailers and trailers, upon the highways of this State unless it is equipped with suitable metal protectors or substantial flexible flaps behind the rearmost wheels of the vehicle or combination to prevent the projection of rocks, dirt, water or other substances to the rear and to minimize side spray.
- (b) The flap, shield or other device shall extend down from the vehicle's body to not more than 8 inches above the road surface, but not more than 15 inches when the vehicle is in an unloaded condition. The protector or flap shall extend laterally at least the width of the tire being protected.
- (c) If any bus or commercial motor vehicle, including semitrailers and trailers, is so designed or constructed that the objectives in subsection (a) of this section are accomplished by reason of fender or body construction or other means of enclosure, either permanent or temporary, then the requirements of this section have been satisfied.
- (d) This section shall not apply to any farm tractor or to uncoupled truck tractors or other vehicles where the construction is such that complete freedom around the wheel area is necessary to secure the designed use of the vehicle.
- (f) Whoever violates this section shall for the first offense be fined not less than \$10 nor more than \$28.75. For each subsequent like offense, the person shall be fined not less than \$28.75 nor more than \$100.

#### **Florida – Florida DOT Office of Motor Carrier Compliance Manual**

##### Splash and Spray Suppressant Devices

- Any truck which exceeds 26,000 pounds gross vehicle weight, any truck tractor, or any trailer or semi-trailer with a net weight of 2,000 pounds or more, shall be equipped with fenders, covers, or other splash and spray suppressant devices, such as flexible flaps, on the rearmost wheels of the vehicle or combination of such vehicles.

## Georgia – Georgia Department of Public Safety Transportation Rulebook 4-393.220

### Tire Covers (wheel flaps; mud flaps)

- Every bus, truck, trailer, semi-trailer, shall be equipped with suitable metal protectors or substantial flexible flaps on the rearmost wheels to prevent, as far as practicable, such wheels from throwing dirt, gravel, rocks, water or other materials on the windshields of following vehicles. Such protectors or flaps shall have a ground clearance of not more than one-half the distance from the center of the rearmost axel to the center of the protector or flap under any conditions of loading of the vehicle and shall be at least as wide as the tire or tires they are covering; provided, however, that if any such bus, truck, trailer, semi-trailer, and pole trailer is so designed and constructed that the foregoing requirements are accomplished by means of fenders, body construction, or other enclosures, then no such protectors or flaps shall be required.

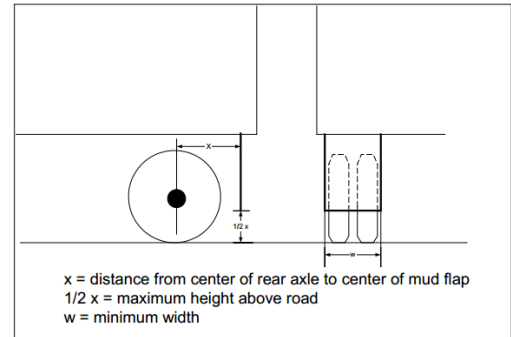

## Idaho – Idaho Department of Motor Vehicles Driver's Manual

### Fenders and Flaps

- All motor vehicles, trailers and semitrailers must have fenders, wheel covers or flaps to prevent mud, water, or other material from being thrown from the wheels up onto other vehicles.

## Illinois – Illinois Vehicle Code Chapter 12, Section 710

### Sec. 12-710. Rear fender splash guards.

- It is unlawful for any person to operate any vehicle of the second division, except a truck tractor, to which this Section is applicable upon any highway of this State unless such vehicle is equipped with rear fender splash guards of either the contour type or the flap type which comply with the specifications provided in this Section for the type of splash guards used on the vehicle, and which are so attached as to prevent the splashing of mud or water upon the windshield of other motor vehicles.
  - (a) Specifications for contour type splash guards. When contour type rear fender splash guards are used, they shall contour the wheel in such a manner that the relationship of the inside surface of any such splash guard to the tread surface of the tire or wheel shall be relatively parallel, both laterally and across the wheel, at least throughout the top 90 degrees of the rear 180 degrees of the wheel surface; provided however, on vehicles which have a clearance of less than 5 inches between the top of the tire or wheel and that part of the body of the vehicle directly above the tire or wheel when the vehicle is loaded to maximum legal capacity, the curved portion of the splash guard need only extend from a point directly behind the center of the rear axle and to the rear of the wheel surface upwards to within at least 2 inches of the bottom line of the body when the vehicle is loaded to maximum legal capacity. There shall be a downward extension of the curved surface which shall end not more than 12 inches from the ground when the vehicle is loaded to maximum legal capacity. This downward extension shall be part of the curved surface or attached directly to such curved surface, but it need not contour the wheel. Such contour type splash guards shall be wide enough to cover the full tread width of the tire or tires being protected and shall be installed not more than 6 inches from the tread surface of the tire or wheel when the vehicle is loaded to maximum legal capacity. The splash guard shall have a lip or flange on its outside edge to minimize side throw and splash. The lip or flange shall extend toward the center of the wheel, and shall be perpendicular to and extend not less than 2 inches below the inside or bottom surface line or plane of the guard. Such contour type splash guards may be constructed of either a rigid or flexible material, but shall be attached in such a manner that, regardless of movement either by the splash

guards or the vehicle, the splash guards will retain their general parallel relationship to the tread surface of the tire or wheel under all ordinary operating conditions.

(b) Specifications for flap type splash guards. When flap type splash guards are used, they shall be wide enough to cover the full tread width of the tire or tires being protected; shall be so installed that they extend from the underside of the vehicle in a vertical plane behind the rear wheels to within 12 inches of the ground, when the vehicle is loaded to maximum legal capacity; shall be so constructed and attached so that when the vehicle is in forward motion such splash guard will not deviate or move backward from the vertical plane by an angle of more than 30 degrees measured from the vertical plane and so that when the forward motion of the vehicle causes such splash guard to deviate from the vertical plane, the bottom of such flap type splash guard will not be more than 15 inches from the ground, when the vehicle is loaded to maximum legal capacity. Such flap type splash guard may be constructed of either a rigid or flexible material.

(c) Exemptions. This Section shall not apply to vehicles the construction or design of which does not require such splash guards, nor to vehicles in-transit and capable only of using temporary splash guards prescribed by the Department, nor to pole trailers.

#### **Louisiana – Louisiana State Revised Statute Section 32-364**

##### Fenders and Mudguards

A. Every motor vehicle, other than a motorcycle or motor-driven cycle, when operated upon a highway of this state, shall be equipped with fenders, covers, or such devices, including flaps or splash aprons, or fender flares to effectively minimize the spray or splash of water or mud or loose material on the highways to the rear of the vehicle unless the body of the vehicle or attachments thereto afford such protection. The width of such fenders, covers, or other devices shall be at least the width of the tires of the motor vehicle.

B. This Section does not apply to those vehicles exempt from registrations, nor to any other vehicle having an unladen weight of under one thousand five hundred pounds, nor to those vehicles which were not supplied with the equipment required in Subsection A of this Section at the time of manufacture, nor to trucks and farm vehicles handling and hauling agricultural and forestry products.

#### **Maine – Maine Revised Statutes Title 29-A: Motor Vehicles, Chapter 17: Equipment, Section 1953**

##### Splash Guards

1. Required. A truck, truck tractor, trailer and semitrailer must be equipped with suitable guards that will effectively reduce the spray or splash of mud, water or slush caused by the rear wheels.

2. Exception. Splash guards are not required for:

A. A truck with a registered gross vehicle weight of 6,000 pounds or less;

B. A dump truck:

(1) While being operated on construction or reconstruction projects in a construction area established by the Department of Transportation; and

(2) On a public way between the project and a pit or quarry where materials are being obtained when the pit or quarry is within 7 miles of the construction area;

C. A truck tractor when not hauling a trailer or semitrailer;

D. A fire department vehicle;

E. A motor vehicle equipped with fenders; or

F. A truck with a stake body that extends not less than 6 feet beyond the rear axle and that is registered under section 505.

#### **Maryland – Maryland Statutes and Codes Section 22-413**

##### Protectors or flaps behind rear wheels of vehicles

(a) Driving certain vehicles in violation of section.- A person may not drive any bus, truck, trailer, or semitrailer on any highway in this State, unless it is equipped with suitable metal protectors or

substantial flexible flaps behind the rear-most wheels of the vehicle or combination of vehicles to prevent the projection of rocks, dirt, water, or other substances to the rear and to minimize side spray.

(b) Causing certain vehicles to be driven in violation of section.- A person may not cause to be driven any bus, truck, trailer, or semitrailer on any highway in this State, unless it is equipped with suitable metal protectors or substantial flexible flaps behind the rear-most wheels of the vehicle or combination of vehicles to prevent the projection of rocks, dirt, water, or other substances to the rear and to minimize side spray.

(c) Permitting certain vehicles to be driven in violation of section.- A person may not permit to be driven any bus, truck, trailer, or semitrailer on any highway in this State, unless it is equipped with suitable metal protectors or substantial flexible flaps behind the rear-most wheels of the vehicle or combination of vehicles to prevent the projection of rocks, dirt, water, or other substances to the rear and to minimize side spray.

(d) Ground clearance of protectors or flaps.- The protectors or flaps shall have a ground clearance of not more than one-third of the horizontal distance from the bottom edge of the protector or flap to the centerline of the axle. However, no protector or flap need be closer to the ground than 6 inches under any condition of loading. The protector or flap shall extend laterally at least the width of the tire or tires being protected.

(e) Construction or design.- If any bus, truck, trailer, or semitrailer, is so designed or constructed that the objectives in subsection (a) of the section are accomplished by reason of fender or body construction or other means of enclosure, either permanent or temporary, then the requirements of this section have been satisfied.

(f) Farm tractors, etc.- This section does not apply to any farm tractor or to any vehicle registered as a farm truck or to uncoupled truck tractors or to pole trailers or other vehicles where the construction is such that complete freedom around the wheel area is necessary to secure the designed use of the vehicle.

#### **Massachusetts – General Laws of Massachusetts Part 1, Title 24, Chapter 90**

Section 7: Brakes, braking systems, mufflers, horns, lights, audible warning systems, and other equipment; compliance with safety standards; stickers and emblems

- Every motor vehicle or trailer, excepting passenger motor vehicles, operated in or upon any way shall be equipped with suitable guards which will effectively reduce the spray or splash to the rear of mud, water or slush caused by the rear wheels thereof. Every passenger motor vehicle which is equipped with tires which extend beyond the fenders or body of such vehicle and which is operated in or upon any way shall be equipped with flaps or suitable guards to reduce such spray or splash to the rear and sides.

#### **Minnesota – Minnesota Statute 169.733**

Wheel Flaps on Truck and Trailer

- Every truck, truck-tractor, trailer, semitrailer, pole trailer, and rear-end dump truck, excepting rear-end dump farm trucks, must be provided with wheel flaps or other suitable protection above and behind the rearmost wheels of the vehicle or combination of vehicles to prevent, as far as practicable, the wheels from throwing dirt, water, or other materials on the windshields of following vehicles. The flaps or protectors must be at least as wide as the tires they are protecting and have a ground clearance of not more than nine inches from the ground when the vehicle is empty.
- For a dump truck or truck with a rigid box fastened to its frame and having a conveyor belt or chain in the bottom of the vehicle that moves the cargo to the rear end of the vehicle, the flaps must be mounted as far to the rear of the vehicle as practicable and have a ground clearance of not more than 18 inches when the vehicle is loaded.
- In addition to meeting the requirements of subdivision 1, a bottom-dump cargo vehicle transporting sand, gravel, aggregate, dirt, lime rock, silica, or similar material must be equipped with a center flap between the wheel flaps, which must have a ground clearance of six inches or less when the vehicle is fully loaded

- If the motor vehicle is so designed and constructed that the above requirements are accomplished by means of body construction or other means of enclosure, then no protectors or flaps are required.
- If the rear wheels are not covered at the top by fenders, body or other parts of the vehicle, the flap or other protective means must be extended at least to a point directly above the center of the rearmost axle.

### **Mississippi – Mississippi Code Title 63: Motor Vehicles and Traffic Regulations Section 63-7-73**

#### Protectors or flaps for rear wheels

(1) No person shall drive or operate or cause to be driven or operated, upon the public highways, streets, bridges and culverts within the State of Mississippi, or any subdivision thereof, any car, truck, truck-tractor, trailer or semi-trailer or bus used for the transportation of property or persons the gross weight of which, including load, exceeds ten tons unless such motor vehicle is equipped with suitable metal protectors or substantial flexible flaps on the rear-most wheels of such vehicle or combination of vehicles, so as to prevent as far as possible such wheels from throwing dirt, water and other materials on the windshields of following motor vehicles. However, pole trailers, dump trucks, and all trucks carrying an "F" license tag shall be exempt from the provisions of this section.

(2) Such protectors or flaps shall be constructed of substantial and suitable materials approved by the commissioner of public safety and shall have a ground clearance of not more than one-fifth of the distance from the center of the rear-most axle to the center of the flaps under any conditions of loading operation of the motor vehicle. They shall be at least as wide as the tires they are protecting. However, if the motor vehicle is so designed and constructed that the purposes of this section cannot be met, then, in the discretion of the commissioner of public safety, no such protectors or flaps shall be required. If the said rear-most wheels are not adequately covered at the top by fenders, body or other parts of the vehicle, the said protectors or flaps shall be extended to a point directly above the rear-most axle. Lamps or wiring shall not be attached to protectors or flaps, and any reflectors or reflectorized material attached to or made a part of the protectors or flaps shall be in addition to the reflectors required by law on the vehicle.

(3) The commissioner of public safety is hereby charged with the duty of administering the provisions of this section.

(4) Any person convicted for a violation of any of the provisions of this section shall for the first violation thereof be punished by a fine of not more than twenty-five dollars (\$ 25.00) or by imprisonment for not more than ten (10) days; for a second conviction such person shall be punished by a fine of not more than one hundred dollars (\$ 100.00) or by imprisonment for not more than twenty (20) days.

### **Missouri – Missouri Statutes and Code Section 307.015**

#### Certain Motor Vehicles, Mud Flaps Required- violations, penalty

- Trucks, semitrailers, and trailers, except utility trailers, without rear fenders, attached to a commercial motor vehicle registered for over twenty-four thousand pounds shall be equipped with mud flaps for the rear wheels when operated on the public highways of this state. If mud flaps are used, they shall be wide enough to cover the full tread width of the tire or tires being protected; shall be so installed that they extend from the underside of the vehicle body in a vertical plane behind the rear wheels to within eight inches of the ground; and shall be constructed of a rigid material or a flexible material which is of a sufficiently rigid character to provide adequate protection when the vehicle is in motion. No provisions of this section shall apply to a motor vehicle in transit and in process of delivery equipped with temporary mud flaps, to farm implements, or to any vehicle which is not required to be registered.
- Any person who violates this section is guilty of an infraction and, upon plea or finding of guilt, shall be punished as provided by law.

### **Montana – Montana Code Annotated Section 61-9-407**

#### Fenders, splash aprons, or flaps required on certain vehicles -- dimension and location

(1) A person may not move, or permit to be moved, a vehicle, except a motorcycle, quadricycle, motor-driven cycle, or farm tractor, as defined in this title, upon the public highways without having first equipped the rearmost wheels or set of wheels of the vehicle with fenders, splash aprons, or flaps. The fenders, splash aprons, or flaps must be designed, constructed, and attached to the vehicle in a manner that arrests and deflects dirt, mud, water, rocks, and other substances that may be picked up by the rear wheels of the vehicle and thrown into the air, as follows:

(a) If the vehicle is equipped with fenders, the fenders must extend in full width from a point above and forward of the center of the tire or tires over and to the rear of the tires.

(b) If the vehicle is equipped with splash aprons or flaps, the splash aprons or flaps must extend downward in full width from a point not lower than halfway between the center of the tire or tires and the top of the tire or tires and to the rear of the tires.

(c) If the vehicle is in excess of 8,000 pounds gross vehicle weight or rating, the fenders, splash aprons, or flaps must extend downward to a point that is not more than 10 inches above the surface of the highway when the vehicle is empty.

(d) If the vehicle is 8,000 pounds or less gross vehicle weight or rating, the fenders, splash aprons, or flaps must extend downward to a point that is not more than 20 inches above the surface of the highway when the vehicle is empty.

(2) Fenders, splash aprons, or flaps, as used in subsection (1), must be constructed as follows:

(a) when measured on the cross-sections of the tread of the wheel or on the combined cross-sections of the treads of multiple wheels, the fender, splash apron, or flap extends at least to each side of the width of the tire or of the combined width of the multiple tires; and

(b) the fender, splash apron, or flap is capable at all times of arresting and deflecting dirt, mud, water, or other substance that may be picked up and carried by the wheel or wheels.

(3) This section does not apply to a street rod as defined in 61-1-101, motor vehicles not originally equipped with fenders, splash aprons, or flaps, or motor vehicles for which fenders, splash aprons, or flaps were not required by federal law or regulation at the time of manufacture.

#### **Nevada – Nevada Revised Statutes Section 484D.420**

##### Mudguards

- Every truck, truck-tractor, trailer, semitrailer or combination of those vehicles having a manufacturer's gross vehicle weight rating of 26,000 pounds or more, when operated upon a highway, must be equipped with mudguards suspended behind its rear wheels.

#### **New Hampshire – New Hampshire Revised Statutes Title 21 Section 266:57**

##### Flaps and Guards

- Every vehicle operated in or upon any way, when not equipped with proper fenders to prevent the throw, spray, or splash of water, dirt, or other matter, shall be equipped with suitable fender guards or flaps which shall effectively reduce the throw, spray or splash likely to be emitted from any wheel or tire. Said flaps or guards required shall be of a type and size prescribed and approved by the director.

#### **New Jersey – Title 39 Motor Vehicles and Traffic Regulations Section 39:3-79.1**

##### Devices to prevent throwing of dirt on windshields of following vehicles

- No person shall operate or cause to be operated any bus, truck, full trailer or semitrailer of registered gross weight exceeding three tons on any public highway unless the same is equipped with suitable metal protectors or substantial flexible flaps on the rearmost wheels, and, in case the rear wheels are not covered at the top by fender, body or other parts of the vehicle, the rear wheels shall be covered at the top by protective means, of such standard type or design and installed in such manner as shall be approved by the Director of the Division of Motor Vehicles in the Department of Law and Public Safety and as shall conform substantially to any requirements of the Interstate Commerce Commission governing similar subject matter, in order to prevent, as far as

practical, such wheels from throwing dirt, water or other materials on the windshields of the following vehicles, except in cases in which the motor vehicle is so designed and constructed that the above requirements are accomplished by reason of fender or body construction or other means of enclosure; provided, however, this act shall not apply to pole trailers, dump trucks, tanks, or other vehicles where the construction thereof is such that complete freedom around the wheel area is necessary to secure the designed use of the vehicle.

## **New York – New York State Consolidated Laws Section 375 Equipment**

### **New York Mud Flap Law**

- (a) On and after the first day of January, nineteen hundred seven- ty-four it shall be unlawful to operate on any public highway or street in this state any tractor, commercial motor vehicle, combination of a commercial motor vehicle and trailer, or combination of a truck-tractor and semi-trailer which is not so constructed or equipped as reasonably to bar water or other road surface substances from being thrown by the rearmost wheels beyond the extreme rear of the vehicle or combination of vehicles, and to minimize side spray.
- (b) Unless the commercial vehicle or combination vehicle is so designed or constructed to accomplish the objectives set forth in para- graph (a) of this subdivision by reason of fender or body construction or other means of enclosure, any such commercial vehicle or combination vehicle shall be equipped, on and after January first, nineteen hundred fifty-seven, with splash guards and stone deflectors which shall be composed of materials substantial enough to withstand ripping or tearing by ordinary means and withstand the action of the elements for a reason- able length of time. Such splash guards and stone deflectors shall also have a reasonable degree of flexibility and the distance from the lower end thereof to the ground shall not exceed one-third of the distance, measured along the ground, from the bottom of the splash guard to the point of contact of the rear wheel.
- (c) The commissioner of motor vehicles is hereby authorized and empowered to make rules and regulations with respect to splash guards and stone deflectors, their type and construction, manner of attachment to vehicles and all other matters requisite for the proper effectuation of the purposes of this subdivision. In making such rules and regu- lations the commissioner shall be guided by the desirability of uniform- ity in requirements with regard to splash guards and stone deflectors among the several states.
- (d) The provisions of this subdivision shall not apply to motor vehi- cles, trailers and semi-trailers registered pursuant to subdivision thirteen of section four hundred one of this chapter, and not operated upon the public highways in excess of one and one-half miles by direct route between farms or portions of farms under single or common owner- ship or operation.

## **Ohio - Ohio Revised Code Section 5577.11**

### **Wheel Protectors**

- No person shall drive or operate, or cause to be driven or operated, any commercial car, trailer, or semitrailer, used for the transportation of goods or property, the gross weight of which, with load, exceeds three tons, upon the public highways, streets, bridges, and culverts within this state, unless such vehicle is equipped with suitable metal protectors or substantial flexible flaps on the rearmost wheels of such vehicle or combination of vehicles to prevent, as far as practicable, the wheels from throwing dirt, water, or other materials on the windshields of following vehicles. Such protectors or flaps shall have a ground clearance of not more than one third of the distance from the center of the rearmost axle to the center of the flaps under any conditions of loading of the vehicle, and they shall be at least as wide as the tires they are protecting. If the vehicle is so designed and constructed that such requirements are accomplished by means of fenders, body construction, or other means of enclosure, then no such protectors or flaps are required. Rear wheels not covered at the top by fenders, bodies, or other parts of the vehicle shall be covered at the top by protective means extending at least to the center line of the rearmost axle.



## Oklahoma – Oklahoma Statute Section 47-12-405.3

### Aprons

- All vehicles or combination of vehicles operating on the highways, except animal-drawn vehicles, not equipped with fenders over the rearmost wheels shall have attached thereto a rubber or fabric apron directly behind the rearmost wheels, and hanging perpendicular from the body of the vehicle. The apron shall be of such a size as to prevent the bulk of the water or any other substance picked up from the roadway from being thrown from the rear wheels of the vehicle or combination of vehicles at tangents exceeding twenty-two and one half (22 1/2) degrees measured from the road surface. The provisions of this subsection shall not apply to a farm tractor moving over the state highway system at a speed less than twenty (20) miles per hour.

## Oregon – Oregon Revised Statutes Section 815.180

(1) There are three different types of fenders and mudguards. Any vehicle required to have fenders and mudguards may be equipped with any fender, cover, flap or splash apron to comply with the requirements of ORS 815.185 (Operation without proper fenders or mudguards) for fenders and mudguards as long as the fenders and mudguards meet all of the following standards:

(a) The width of any fender or mudguard required under this section must be of sufficient size so that the fender or mudguard extends at least to each side of the width of the tire or combined width of the multiple tires when measured against the cross section of the tread of the wheel or the combined cross sections of the treads of the multiple wheels.

(b) Any fender or mudguard required under this section must be of sufficient size and must be so constructed as to be capable at all times of arresting and deflecting any dirt, mud, water or other substance that may be picked up and carried by the wheels.

(2) The following types of fenders or mudguards must cover the wheels of the vehicle in the manner described in paragraphs (a), (b) and (c) of this subsection:

(a) Type I fenders or mudguards must extend in full width from a point on the wheels that is above and forward of the center of the tires over to a point at the rear of the wheels that is not more than 10 inches, or, if attached to the rear of a dump box that elevates for unloading, not more than 13 inches, above the surface of the highway when the vehicle is empty.

(b) Type II fenders or mudguards must extend downward in full width from a point behind the wheels that is not lower than halfway between the center of the wheels and the top of the tires to a point at the rear of the wheels that is not more than 10 inches above the surface of the highway when the vehicle is empty.

(c) Type III fenders or mudguards must extend in full width from a point on the wheels that is above and forward of the center of the tire over a point at the rear of the wheel that is not more than 27 inches above the surface of the highway

### Special Transportation Permit: Attachment 24

#### Splash and Spray Suppressant Device Requirements

- Each vehicle combination exceeding 80,000 pounds, and all triple trailer combinations regardless of weight, are required to obtain an Extended Weight Variance Permit. In addition to the mudguard/fender requirements described in ORS 815.180 and ORS 815.182, vehicle combinations exceeding 80,000 pounds, and all triple trailer combinations regardless of weight, are required to comply with the following minimum splash and spray devices when wet road conditions exist:

#### Minimum Splash and Spray Suppressant Device Requirements:

##### A. Mudguards, Fenders are required:

(1) The mudguard or fender must be installed behind each axle, tandem axle or group of axles, and behind any axle where the distance between the inside tread of two consecutive axles is more than 5' apart;

- (2) The mudguard or fender shall be placed no more than 5' behind the rear tire of each axle that requires a mudguard or fender; and;
- (3) The mudguard or fender must comply with the requirements described in ORS 815.180 and ORS 815.182, shall not be more than 10" above the surface of the highway or, if attached to the rear of a dump box that elevates for unloading, not more than 13" above the surface of the highway, and cannot be more than 5' behind the tread of the last axle.

B. Side Skirts are required and:

- (1) Must be installed on all non-pivoting axle(s);
- (2) Must be attached to the vehicle at the forward most point to the rear most point of the tread of each tire considered separately. Except to allow for clearance lights and tie down devices, there shall not be a gap at the top of the side skirt where it attaches to the vehicle;
- (3) Must be constructed of a stiff, durable material that is impervious to water and capable of deflecting water or other wet substances that may be picked up and carried by the tires or wheels. Bristle type material(s), also known as Hula Skirts, may qualify as a side skirt as long as they meet the placement standards shown in this section.
- (4) In lieu of a side skirt, a fender with an outer lip extending from the body of the vehicle may be used providing it meets the side skirt requirements (1) through (3) shown above.

Exempt from Splash and Spray Suppressant Device Requirements:

- A motor truck that is not equipped with a body (for example a log truck);
- A pole trailer

Exempt only from the Side Skirts Splash and Spray Suppressant Device Requirement:

- A jeep;
- A booster;
- A lowboy;
- A container chassis;
- A frame rail trailer

Figure 1 - Placement of Mudguards or Fenders & Side Skirts

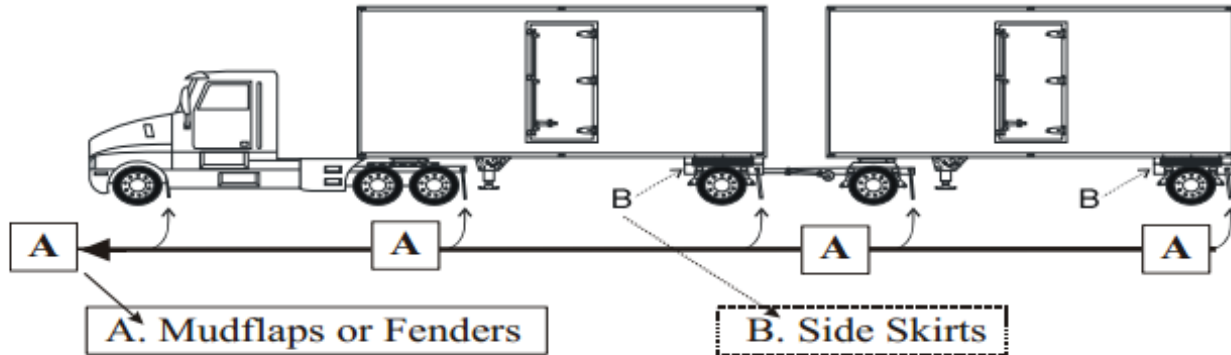

Figure 2 - Side Skirt Requirement

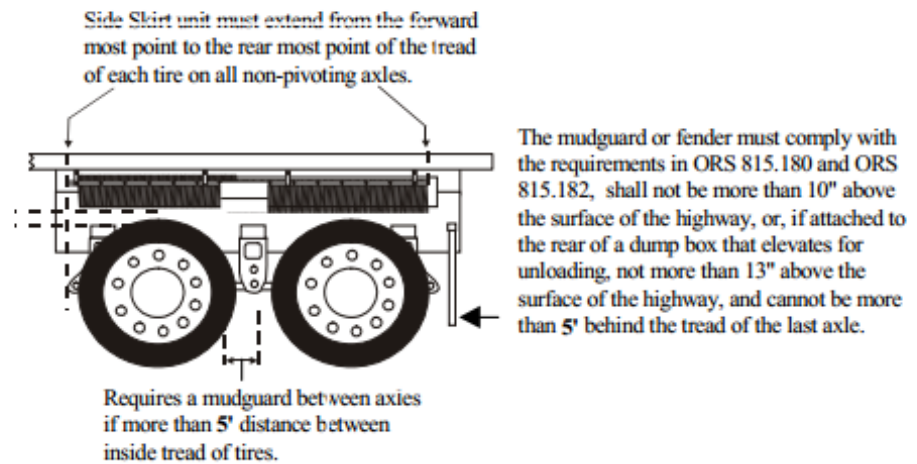
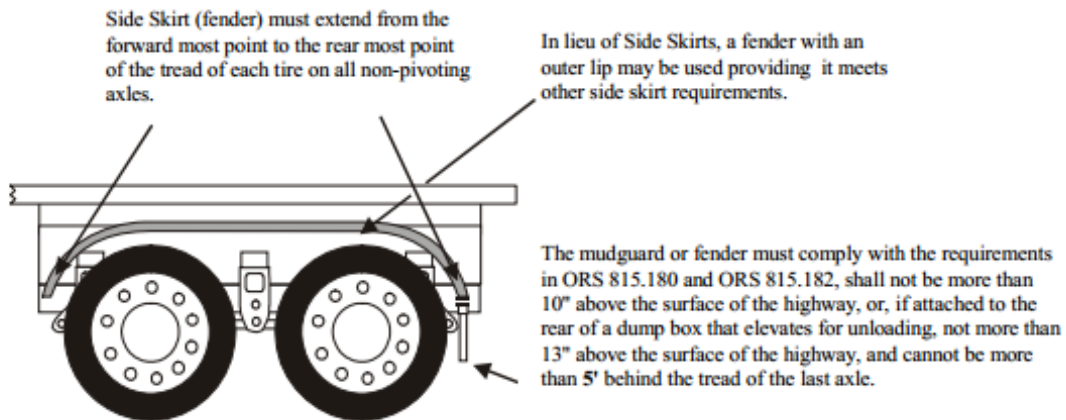

Figure 3 - Fender (Side Skirt) Requirement



## **Pennsylvania – The Pennsylvania Code Section 175.108 and Section 175.126**

### Subchapter F – Medium and Heavy Trucks and Buses

(g) *Fenders and flaps.* A vehicle specified under this subchapter shall be equipped with fenders which provide at least as much coverage of the wheel as original equipment. Wheels shall be sufficiently covered with fenders or flaps to prevent loose objects, rain, snow and the like from being thrown about in a manner which may interfere with other persons using the highways.

(h) *Rear wheel shields.* A vehicle specified under this subchapter, except a truck-tractor while towing a trailer, shall be constructed or equipped to bar water or other road surface substances thrown from the rear wheels of the vehicle or combination at tangents exceeding 22.5°, measured from the road surface, from passing in a straight line to the rear of the vehicle or combination. See 75 Pa.C.S. § 4533 (relating to rear wheel shields).

### Subchapter G – Recreational, Semi and Utility Trailers

(e) *Fender and flaps.* The wheels of a trailer originally manufactured with fenders or flaps shall be equipped with fenders or flaps of a type used as original equipment.

(f) *Rear wheel shields.* A trailer shall be constructed or equipped so as to bar water or other road surface substances thrown from the rear wheels of the vehicle or combination at tangents exceeding 22 1/2°, measured from road surface, from passing in a straight line to the rear of the vehicle or combination. See 75 Pa.C.S. § 4533 (relating to rear wheel shields).

## **Rhode Island – Rhode Island General Laws Section 31-23-26**

### Fender and Wheel Flaps Required

- No person shall operate any motor vehicle on any public highway of this state unless the vehicle is equipped with fenders covering the front wheels of the motor vehicle, or operate any passenger motor vehicle on any public highway equipped with tires which extend beyond the fenders or body of the vehicle unless it is also equipped with flaps or suitable guards to reduce spray or splash to the rear and sides. Violations of this section are subject to fines enumerated in § 31-41.1-4.

## **Tennessee – Tennessee Code Section 55-9-212**

### Mudguards on trucks Penalty

(a) No person shall operate upon a public highway or street any motor vehicle, including a separate truck tractor (normally used in a tractor-trailer combination), or combination of vehicles having a carrying capacity in excess of three thousand pounds (3,000 lbs.), if the motor vehicle or combination of vehicles is not equipped with rear fenders, mud flaps or mudguards of such size as to substantially prevent the projection of rocks, dirt, water or other substances to the rear. The fenders, flaps or guards shall be of a type approved by the commissioner of safety.

(b) This section shall have no application to farm vehicles, or vehicles used by farmers to haul produce from farm to market, nor shall it apply to vehicles used exclusively for hauling logs.

(c) A violation of this section is a Class C misdemeanor.

## **Texas – Texas Statutes Section 547.606**

### Safety Guards or Flaps Required

(a) A road tractor, truck, trailer, truck-tractor in combination with a semitrailer, or semitrailer in combination with a towing vehicle that has at least four tires on the rearmost axle of the vehicle or the rearmost vehicle in the combination shall be equipped with safety guards or flaps that:

- (1) Are of a type prescribed by the department; and
- (2) Are located and suspended behind the rearmost wheels of the vehicle or the rearmost vehicle in the combination within eight inches of the surface of the highway.

(b) This section does not apply to a truck-tractor operated alone or a pole trailer.

## **Utah – Official Vehicle Safety Inspection Manual For Tractors/Trailers/Buses 26,001 lbs GVWR and Above –Section 2**

### Rear Wheel Mudguards

1. Check vehicle for proper mudguard protection. Mudguards, flaps, or splash aprons shall: be at least as wide as the tires they are protecting, be directly in line with the tires, and maintain a ground clearance of not more than 50% of the diameter of a rear-axle wheel, under any conditions.

### REJECT when:

- 1) Tire tread is not fully covered by body, trailer or fender.
- 2) Rear tires do not have the top 50% of the tire covered by mud flaps.
- 3) Rear mud flaps are not as wide as the tire.

\*NOTE: Wheel covers; mudguards, flaps or splash aprons are not required if the motor vehicle, trailer, or semi-trailer is designed and constructed so that it meets the above requirements (UCA 41-6a-1633).

## **Vermont – Vermont Statutes Title 23: Motor Vehicle Chapter 13: Operation of Vehicles Sub-Chapter 14: Equipment Section 1306**

### Rear Wheel Flaps

- No person may operate or cause to be operated any bus, truck, trailer, or semi-trailer upon any highway in this state unless the bus, truck, trailer, or semi-trailer is equipped with suitable metal protectors or substantial flexible flaps behind the rearmost wheels to prevent, as far as practicable, the wheels from throwing dirt, water, or any other materials on the windshields of vehicles following or approaching. The flaps shall be of a type and size as specified by the motor vehicle department. However, this section shall not apply to farm tractors or pole trailers.

## **Virginia – Code of Virginia Section 46.2-1083**

### Rear fenders, flaps, or guards required for certain motor vehicles

- No person shall operate on a highway any motor vehicle or combination of vehicles having a licensed gross weight in excess of 40,000 pounds unless the motor vehicle or combination of vehicles is equipped with rear fenders, flaps, or guards of sufficient size to substantially prevent the projection of rocks, dirt, water, or other substances to the rear. Vehicles used exclusively for hauling logs and tractor trucks shall be exempt from the provisions of this section.

## **Washington – Revised Code of Washington Section 46.37.500**

### Fenders or splash aprons

- (1) Except as authorized under subsection (2) of this section, no person may operate any motor vehicle, trailer, or semitrailer that is not equipped with fenders, covers, flaps, or splash aprons adequate for minimizing the spray or splash of water or mud from the roadway to the rear of the vehicle. All such devices shall be as wide as the tires behind which they are mounted and extend downward at least to the center of the axle.
- (2) A motor vehicle that is not less than forty years old or a street rod vehicle that is owned and operated primarily as a collector's item need not be equipped with fenders when the vehicle is used and driven during fair weather on well-maintained, hard-surfaced roads.

## **Wisconsin – Wisconsin Code Section 305.53 and 347.46**

### 305.53 Fenders and Mud Guards

- Every trailer or semi-trailer shall be equipped with adequate fenders to cover the tires, except when the construction of the trailer or semitrailer is such that the body, bed, load, or load-carrying area covers the tires. Semitrailers operated in intercity movement and not equipped with dump bodies shall have sufficient mud guards as specified in s. 347.46 (2), Stats., unless exempted under s. 347.46 (2) (c), Stats.

### 347.46 Fenders and mudguards.

(1) No person shall operate a vehicle of the tractor type on a highway unless the driving wheels of such vehicle are protected by suitable fenders.

(2) No person shall operate on a highway in intercity movement any privately owned motor truck or privately owned semitrailer drawn by a truck tractor, except those motor trucks and semitrailers equipped with dump bodies, unless such motor truck or semitrailer is equipped with rear fenders or mudguards of such material and so constructed and placed as to restrict to a minimum the splashing of water, mud or other material which may be thrown by the rear wheels. Such rear fenders or mudguards shall meet the following minimum specifications:

(a) The fenders or mudguards shall cover the tire or multiple tires they are protecting starting at the top from a line drawn vertically through the center of the axle and extending rearward and downward so that the fender or mudguard under any condition of operation or loading of the vehicle has a ground clearance of not more than one third of the horizontal distance from the center of the rearmost axle to the fender or mudguard;

(b) The fenders or mudguards shall be at least as wide as the tire or multiple tires they are protecting;

(c) If the vehicle is so designed and constructed that the rear wheels are covered in the manner specified in pars. (a) and (b) by means of fenders, body construction or other means of enclosure, then no special mudguards are required. Otherwise, the vehicle shall be equipped with special mudguards to the extent necessary to meet the requirements of pars. (a) and (b).

**FMCSA** – FMCSA does not have a specific FMCSR regarding mud flaps, splash guards, or fenders. However, they have recommend that mud flaps be mounted at 300 mm and at angle greater than 22 degrees.

**States with no mention of fender or mud flap requirements:** Alabama, Arkansas, Colorado, Hawaii, Indiana, Iowa, Kansas, Kentucky, Michigan, Nebraska, New Mexico, North Carolina, North Dakota, South Carolina, South Dakota, West Virginia, Wyoming.

Contact: Abigail Potter [apotter@trucking.org](mailto:apotter@trucking.org)